



**Aalto University**  
School of Science  
and Technology

# Implementation of Regression Class based CMLLR

**Peter Smit**

peter.smit@tkk.fi

users.ics.tkk.fi/peter

*Speech Group*

*Adaptive Informatics Research Centre*

**December 7, 2010**

# Outline

Introduction

Regression Class

CMLLR

CMLLR

Regression Class

Trees

Implementation

Details

Results

Conclusion

## Introduction

## Regression Class Tree Constrained Maximum Likelihood Linear Regression

Constrained Maximum Likelihood Linear Regression  
Regression Class Trees

## Implementation

Details  
Results

## Conclusion



# The assignment

## Introduction

Regression Class

CMLLR

CMLLR

Regression Class  
Trees

Implementation

Details

Results

Conclusion

- Work done as Summer Trainee in summer 2009
- Assignment was to implement Regression Class Tree CMLLR in the TKK speech recognizer (aku)
- 'global' CMLLR implementation was already present in aku



# How does Speech Recognition work

## Introduction

Regression Class

CMLLR

CMLLR

Regression Class

Trees

Implementation

Details

Results

Conclusion

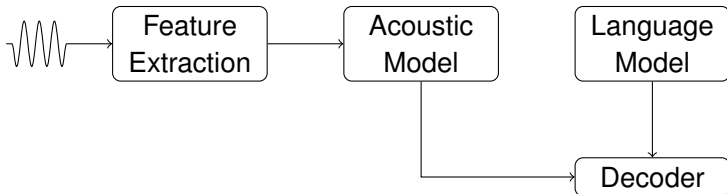

# How does Speech Recognition work

## Introduction

Regression Class

CMLLR

CMLLR

Regression Class

Trees

Implementation

Details

Results

Conclusion

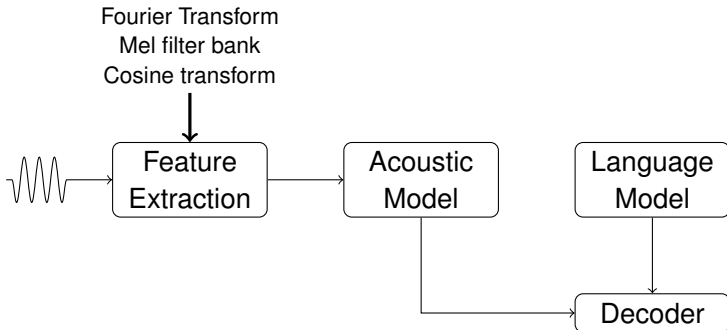

# How does Speech Recognition work

## Introduction

Regression Class

CMLLR

CMLLR

Regression Class

Trees

Implementation

Details

Results

Conclusion

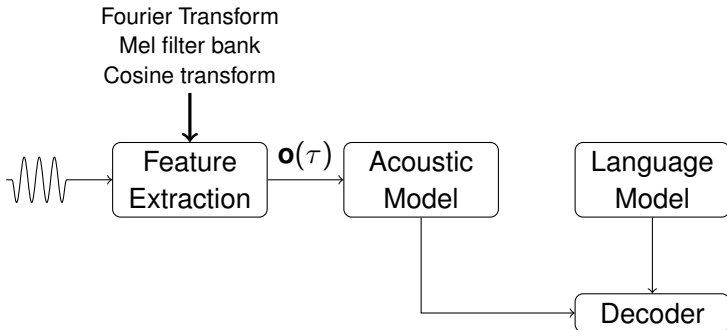

# How does Speech Recognition work

## Introduction

Regression Class

CMLLR

CMLLR

Regression Class

Trees

Implementation

Details

Results

Conclusion

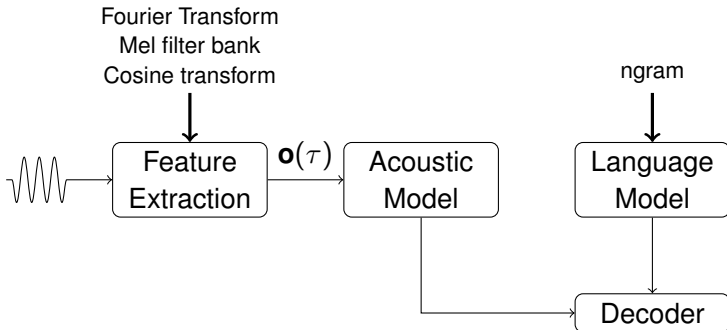

# How does Speech Recognition work

## Introduction

Regression Class

CMLLR

CMLLR

Regression Class

Trees

Implementation

Details

Results

Conclusion

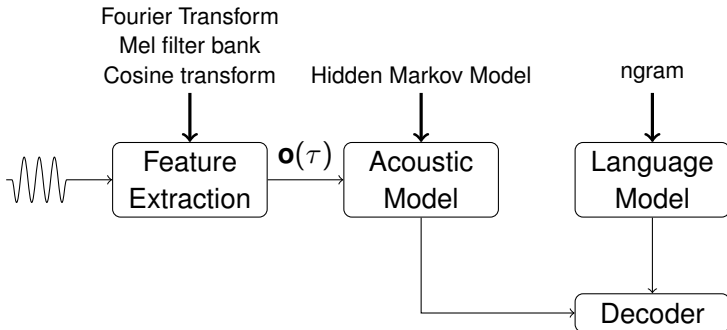

# Acoustic Model

## Introduction

Regression Class

CMLLR

CMLLR

Regression Class

Trees

Implementation

Details

Results

Conclusion

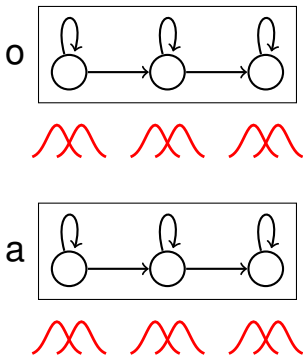

# Speaker Adaptation

## Introduction

Regression Class  
CMLLR  
CMLLR  
Regression Class  
Trees

Implementation  
Details  
Results

Conclusion

- An ASR system is Speaker Dependent or Speaker Independent
- A SD system is more expensive, gives good performance for known speaker
- A SI system is less expensive, gives average performance for all speakers
- Adaptation transforms a SI model to a SD model with some adaptation data



# Maximum Likelihood Linear Regression

Introduction

Regression Class

CMLLR

CMLLR

Regression Class  
Trees

Implementation

Details

Results

Conclusion

Idea:

- Find a linear transformation for the means and / or variance of the emission distributions that maximizes the likelihood of some adaptation speech + transcription
- Mean-MLLR:  $\hat{\mu} = \mathbf{A}\mu + \mathbf{b}$
- Variance-MLLR:  $\hat{\Sigma} = \mathbf{B}^T \mathbf{H} \mathbf{B}$  where  $\mathbf{H}$  is the transform, and  $\mathbf{B}$  the inverse Choleski factor of  $\Sigma$



# Constrained Maximum Likelihood Linear Regression

Introduction

Regression Class

CMLLR

CMLLR

Regression Class

Trees

Implementation

Details

Results

Conclusion

- Use the same transform for the mean and the variance.
- Mean transform:  $\hat{\mu} = \mathbf{A}^{-1}\mu - \mathbf{b}^{-1}$
- Variance transform:  $\hat{\Sigma} = \mathbf{A}^{-1}\Sigma\mathbf{A}^{-1T}$



# Transforming the feature vectors instead

Introduction

Regression Class

CMLLR

CMLLR

Regression Class

Trees

Implementation

Details

Results

Conclusion

- This transform makes from a diagonal covariance a full covariance model. This is bad for computation times
- Move the transform to the feature vectors:  $\mathbf{A}\mathbf{o}(\tau) + \mathbf{b}$

Estimating the transforms:

$$\arg \max_{\mathbf{A}, \mathbf{b}} L(\mathbf{A}\mathbf{o}(\tau) + \mathbf{b} | \mu, \Sigma)$$



# Regression Classes

Introduction

Regression Class

CMLLR

CMLLR

Regression Class  
Trees

Implementation

Details

Results

Conclusion

- Group similar gaussians together in a class
- Use for every class a different transform



# Regression Classes

Introduction

Regression Class

CMLLR

CMLLR

Regression Class  
Trees

Implementation

Details

Results

Conclusion

- Group similar gaussians together in a class
- Use for every class a different transform
- How can we group these gaussians?
- How much classes?
  - Depends on the amount of adaptation data
  - Every transform needs a minimum amount of adaptation data to be robustly estimated



# Regression Class Tree

Introduction

Regression Class

CMLLR

CMLLR

Regression Class  
Trees

Implementation

Details

Results

Conclusion

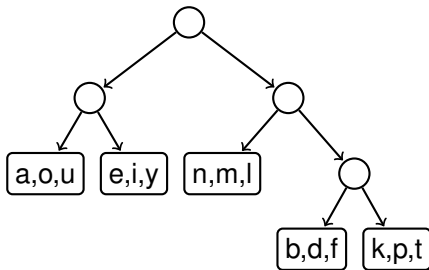

# Regression Class Tree - Building

Introduction

Regression Class

CMLLR

CMLLR

Regression Class  
Trees

Implementation

Details

Results

Conclusion

- Put all Gaussians together in same node
- Divide gaussians over two sibling with iterative procedure (“weighted k-means”)
- Stop when a node only contains one Gaussian, or when the max number of nodes is reached



# Regression Class Tree - Usage

Introduction

Regression Class

CMLLR

CMLLR

Regression Class  
Trees

Implementation

Details

Results

Conclusion

- Gather statistics for each terminal node in the tree separately
- Test or a node has enough data (occupancy)
  - If no, merge with sibling
  - If yes, make new transform for this node



# Implementation details

Introduction

Regression Class

CMLLR

CMLLR

Regression Class

Trees

Implementation

Details

Results

Conclusion

- Rewritten original CMLLR implementation
- Made a generic model transform framework
- Made a tool for generating the Regression Class Trees
- All implementations done in C++



# Results

Introduction

Regression Class

CMLLR

CMLLR

Regression Class

Trees

Implementation

Details

Results

Conclusion

- On the Finnish Speecon dataset, Regression Class CMLLR had no improvement over normal CMLLR
- On English Law text, big improvements were made (experiments done by André Mansikkaniemi)



# Results - English Law text

Introduction

Regression Class

CMLLR

CMLLR

Regression Class

Trees

Implementation

Details

Results

Conclusion

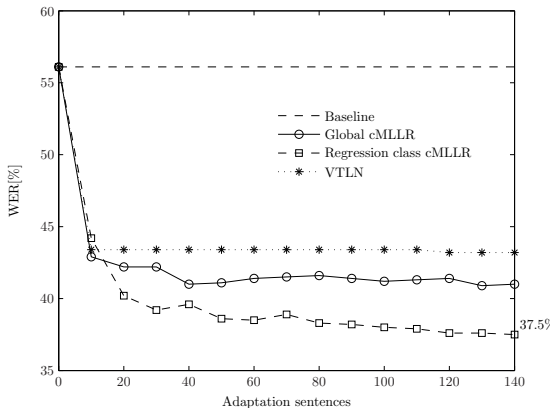

# Conclusion

Introduction

Regression Class

CMLLR

CMLLR

Regression Class

Trees

Implementation

Details

Results

Conclusion

- Nice project to work on
- Knowledge will be used extensively in my Master's Thesis



# Questions?

Introduction

Regression Class

CMLLR

CMLLR

Regression Class

Trees

Implementation

Details

Results

Conclusion

- Questions?

- Slides and report can be found at [users.ics.tkk.fi/peter](http://users.ics.tkk.fi/peter)

